

[Table of contents]

Introduction	<p>[1] For use with motors</p> <p>(1)What does a capacitor do in a motor ?</p> <p>(2)The difference between a motor start capacitor and a motor run capacitor.</p> <p>(3)Voltage on capacitor</p> <p>(4)Capacitance</p> <p>(5)3 phase motors</p>
	<p>[2] For use with lighting</p> <p>(1)What does a capacitor do in lightings?</p> <p>(2)"parallel" compensation and "series"compensation.</p> <p>(3)Discharge resistor</p> <p>(4)Operating conditions</p>
	<p>[3] Safety of the capacitors</p> <p>(1)Self-healing</p> <p>(2)PSI(Pressure Sensitive Interrupter)</p>
	<p>[4] Circuit design considerations</p>

[Introduction]

● "CAPAKOR" has offered wide and diversified range of AC film capacitors for electrical appliances, in particular for use in; motor, pump, air conditioning, compressor, lighting and general purpose AC applications.

"CAPAKOR" AC film capacitors for electrical appliances are manufactured with self-healing metallized film, designed for, in particular,

- ① operation of a single phase induction motor
- ② improve the power factor on discharge lamps

[1] For use with motors

(1) What does a capacitor do in a motor ?

There are probably more single phase induction motors in use today than total of all the other types put together, every home, workshop has them.

The problem with the single phase induction motor is its inability to develop a "rotating magnetic field" of its own accord.

Without a "rotating magnetic field", torque cannot be developed, and rotor will never turn.

To provide the "rotating magnetic field" necessary to turn the rotor, most all of single phase induction motors are "Capacitor run motors".

Capacitors perform the role of creating a power supply with the phase shift that is required for creating such a "rotating magnetic field".

As shown in the below fig.s, "Capacitor run motors" are, in addition to the main winding, equipped with an auxiliary winding in the stator offset by 90 electric degrees from the main winding.

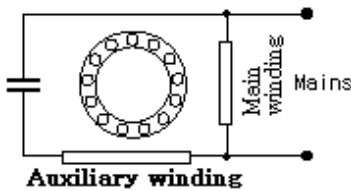

[General motor run application]

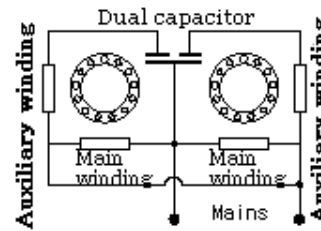

[Air-conditioning circuit :compressor and fan application]

The capacitor is permanent connected to in series with the auxiliary winding, causing the current in the auxiliary winding to lag the current in the main winding and produce a time delay between the magnetization of the both windings, and "rotating magnetic field" exists.

Thus, single phase induction motors become self-starting by using combinations of inductance and capacitance to apply out-of phase current in auxiliary winding.

In the capacitor-run motor, the run capacitor and the auxiliary winding are connected for the entire time the motor is running, this will preserve the "rotating magnetic field" and improve torque at operating speed.

However, this requires a heavier winding in order not to overheat, and the motor run capacitor rated for full-time use.

Typical applications include domestic appliances, compressors, pumps, fans, refrigerators, air conditioners and office machinery.

They are also suitable for use with 3-phase motors in star connection operating from a single power supply.

(2) The difference between a motor start capacitor and a motor run capacitor.

Some motors used in applications that start against high loads such as compressors use an additional capacitor during the first few seconds of operation to provide higher starting torque.

When the motor is up to speed, a switch automatically disconnects the start capacitor.

These motor start capacitors are typically of the electrolytic capacitor and large in value and are not interchangeable with motor run capacitor, since the motor run capacitor is connected for the entire time the motor is in operation.

An electrolytic capacitor used in AC circuit for more than a few seconds will overheat and possibly catch fire.

The motor run capacitors not only provide to assist motor-starting, but also improve the motor power factor, torque and efficiency since the motor is basically a 2-phase motor.

(3) Voltage on capacitor

The voltage developed across the capacitor can reach approximately 1.5 times supply voltage, under no-load conditions (for example; a motor operating from a 220VAC mains will normally take a running capacitor rated at 350/300VAC).

Therefore, careful selection of the capacitor voltage rating is therefore essential.

(4) Capacitance

The choice of the capacitance is usually empirically made on the motor.

This is because of differences between different motor manufacturers.

If too much capacitance is used the auxiliary winding can become overloaded, resulting in reduced starting torque and increased heat while running.

(5) 3 phase motors

By contrast, always supply power with different phases, so they do not require capacitors.

[2] For use with lightings

(1)What does a capacitor do in lightings?

All the discharge lamps like fluorescent lamps,mercury lamps,metal-hallogen lamps and sodium lamps require a ballast to stabilize the electric arc.

Since the ballast constitutes an inductance,the discharge lamp circuits have an inherent low power factor around $\cos\phi=0.4 \sim 0.5$. Low power factor indicates poor utilization of electric power.

Therefore,all Electricity Regulatory Authorities require that power factor for lighting installations be corrected to a value of $\cos\phi=0.9$. The necessary correction of the power factor to $\cos\phi=0.9$ is achieved by adding lighting capacitors of suitable capacitance to the circuit.

(2) "parallel" compensation and "series"compensation.

Lighting capacitors for improvement the power factor on discharge lamps,using 2 installation systems:"parallel" compensation and "series"compensation.

①"Parallel" compensation circuit

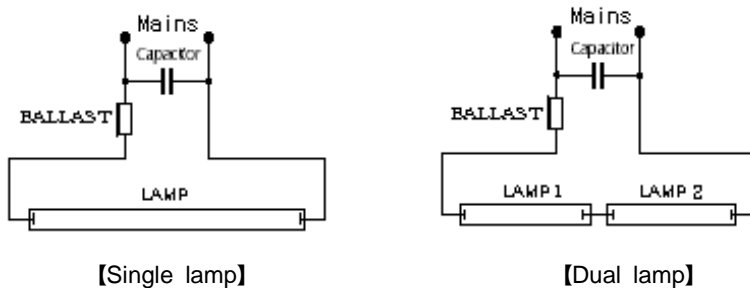

②"Series" compensation circuit

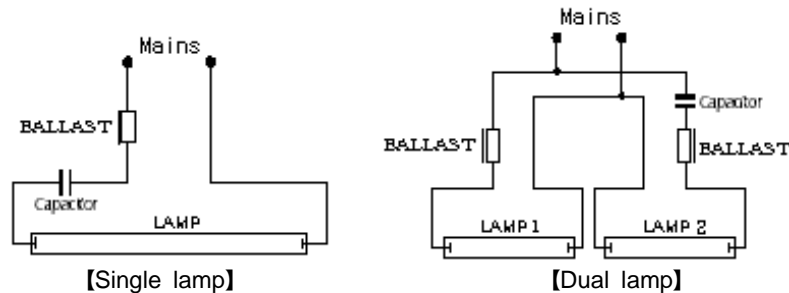

"Parallel"compensation	"Series"compensation
①"Parallel"compensation is the type of power factor correction most generally used. ②the capacitor is shunt-connected to the mains. ③voltage across the capacitor is the same of the mains. ④the capacitor used generally have $\pm 10\%$ tolerance.	①the capacitor is connected in series on the mains. ②today less and less used,mostly used in dual lamp circuit. ③voltage across the capacitor is higher than that of the mains(for example:from a 250VAC mains supply will normally take a capacitor rated at 450VAC). ④the capacitor used generally have narrower tolerance($\pm 3\%$) as the capacitance is critical.

(3)Discharge resistor

Since capacitors can retain their charge for a considerable time after they have been disconnected ,the standard (EN61048)states that a suitable resistor should be connected to the capacitor to ensure that after the circuit is broken, the capacitor discharges,in 1 minute, from the rated voltage to a residual voltage $\leq 50V$.

"CAPAKOR" capacitors are provided with internal or external discharge resistors which is fitted across the capacitor winding to ensure that the voltage across the capacitor is reduced to less than 50V 1 minute after disconnection ,for maximum safety and reliability, upon request.

(4)"standard" and "heavy duty"capacitor.

The capacitors for use with lightings are generally located inside the fittings,then the operating temperature is always high.

For provide constant service in these widest climatic and thermal conditions,

"CAPAKOR"has developed 2 class of the capacitors for use with lightings: "standard"capacitor and "heavy duty"capacitor.

standard	heavy duty(for high ambient temperature or very humid climatic conditions)	
	for parallel compensation	for series compensation
①MLC62P0series(aluminum case)/MLC06P0series and MLC99PO series(plastic case). ②used preferably on fluorescent lamp ③voltage $\leq 250V$ ④ambient humidity:standard	①MLC62P1 series(aluminum case) ②used preferably on HID lamp, street lighting ③voltage $\leq 280V$ ④with PSI	①MLC62P1 series(aluminum case) ②voltage $\leq 450V$ ③with PSI



[3] Safety of the capacitors

"CAPAKOR" AC film capacitors for electrical appliances offer the highest safety with double safety systems, self healing and PSI (Pressure Sensitive Interrupter).

(1) PSI (Pressure Sensitive Interrupter)

Our capacitors series with safety class:P1 contain a built-in PSI (Pressure Sensitive Interrupter), UL recognized rating 10,000AFC. This device is designed to sense the build-up of pressure within the capacitor if a fault occurs and to internally disconnect the electrical connection, and removes capacitor from line before internal pressure can cause the case rupture.

The fig. below illustrates the way the capacitor internal protection (Pressure sensitive device) works on the event of a failure, disconnecting the tabs from the terminal on the capacitor cover, cutting the power supply to avoid the capacitor to burst on the event of a capacitor internal failure.

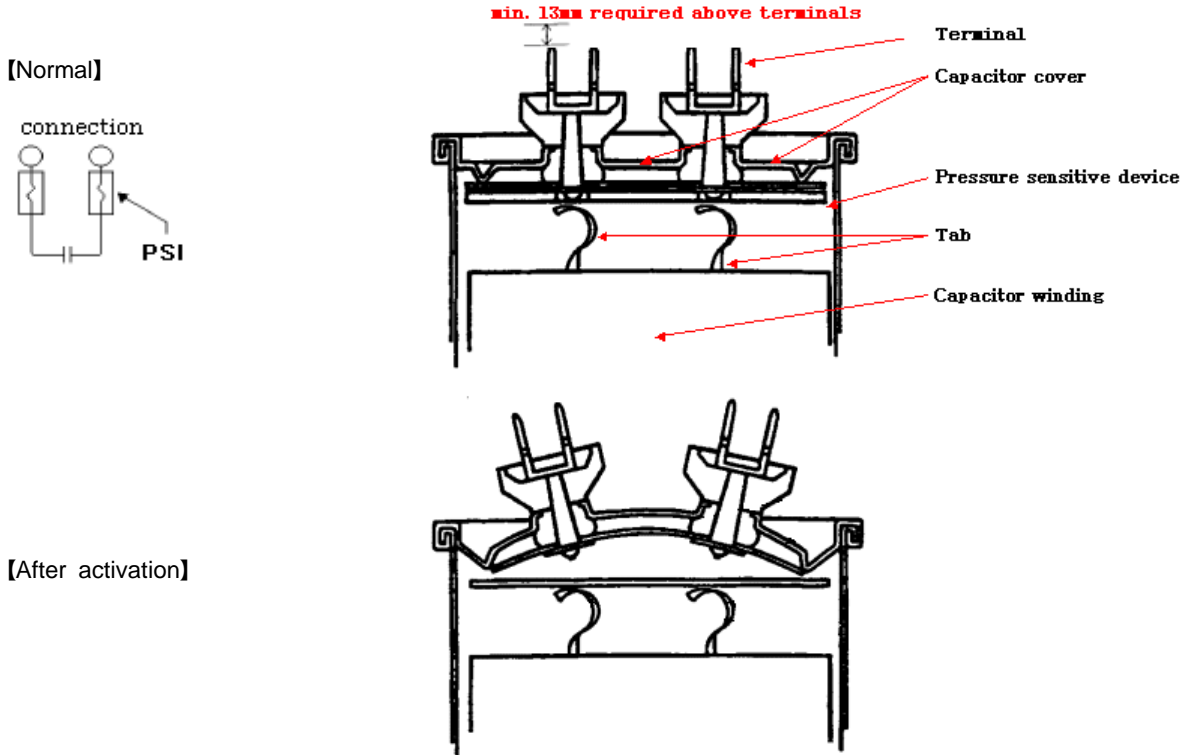

Connections to capacitor winding are made with tabs welded to each end and connected to the terminals through an Pressure sensitive device.

Capacitor cover is normally flat and the tabs are connected to the terminals.

Each time the capacitor self-heals a small volume of gas is produced.

In the event of overvoltage or ageing at the end of the capacitor's useful service life, an increasing number of self-healing breakdowns may cause rising pressure inside the capacitor.

The gradual build-up of gas or internal pressure increases on the event of an internal failure bulges the cover.

Then, tabs are disconnected from the cover by the pressure sensitive device.

This creates an open circuit before the case can rupture, and the current to the capacitor windings is interrupted irreversibly, before the case can rupture.

This very important feature prevents a potentially dangerous catastrophic failure.

When this happens: in a motor application: the motor may refuse to run or will run slowly,

in an air conditioner application: the compressor and/or the fan will fail to start,

in a lighting application: the light may grow dim or refuse to light.

When mounting capacitors with PSI, make sure that the mounting position of the capacitors will not affect the operation of the PSI.

To ensure proper operation;

① the connecting terminals must be sufficiently elastic.

② there must be enough space left for expansion above the terminals of capacitor cover.

③ capacitors must be installed with a minimum of 13mm of clearance between terminals or cover and any external restriction.

④ capacitors usually be mounted upright, i.e. terminals on top.

(2) Self-healing

All dielectric structure used in AC motor & Lighting capacitors are "self-healing".

An electric breakdown is possible as the result of thermal or electric overload or at the end of service life.

A breakdown results in a small arc that evaporates the extremely thin metalized electrode in the region of the breakdown and the gas pressure generated in the center of the breakdown spot by high temperature blows vaporous metalized electrode out of the breakdown region within 10 micro-seconds.

Thus a non-conductive insulating area, free of metalization is formed here.

During and after the breakdown, the capacitor is fully functional.

The reduction in capacitance caused by self-healing is less than 100pF, that can only be verified by a precision measuring

instrument.

During the self-healing only a fraction of the energy stored in the capacitor is dissipated with the self-healing. Extensive and continuous self-healing(at misapplications)will gradually decrease the capacitance value.

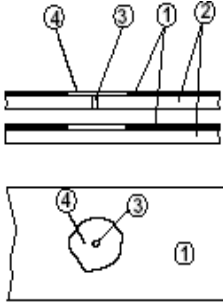

Self-healing breakdown

- ① Electrodes (metallized)
- ② Dielectric film
- ③ Point of breakdown
- ④ Non-conductive insulating area

[4] Circuit design considerations

(1) Selection of rated voltage (URAC)

- ① The rated voltage of capacitors for electrical appliances is usually specified as the rms value of the sinusoidal AC voltage.
- ② The voltage developed across the capacitor.
- ③ In the motor run application, can reach approximately 1.5 times supply voltage, under no-load conditions (for example; a motor operating from a 220VAC mains supply will normally take a running capacitor rated at 350/300VAC).
- ④ However, in the lighting application, same of the mains at "Parallel" compensation or higher than the mains at "Series" compensation. Therefore, careful selection of the capacitor voltage rating is essential.
- ⑤ It must also be considered that at the moment of switching, voltage transients may occur on the capacitor. In addition to the normally operated terminal voltage, it is necessary to pay attention to rated frequency, load fluctuation and voltage change caused by a connection with other electrical parts, for selection of URAC.
- ⑥ Max. permissible continuous overvoltage, including changes in the source voltage, is less than 110% of URAC. If supply voltage fluctuation exceeds +10%, the URAC should be raised.

(2) Operating temperature range.

- ① Max. permissible temperature
Capacitors should be used within the max. permissible temperature specified. The temperature is defined as T_h (the highest temperature on any area of capacitor case).
 $T_h = \Delta T$ (capacitor's temperature rise due to self-heating) + T_a (ambient temperature).
* ΔT : capacitor's self-generated temperature rise value by internal heating due to flowing current.
* The T_a upper limit value will vary according to the conditions such as heat transmission and radiation from nearby heat-generating source or little air convection.
Take care not to mount the capacitor in areas close to devices radiating a strong heat and, if necessary, adequate heat dissipation must be ensured by ventilating the space in which the capacitors are mounted.
- ② Min. permissible temperature
Capacitors should be used at T_a above the min. permissible temperature specified.
- ③ If capacitors are used at frequencies other than Rated frequency (50/60Hz), or at steep voltage rises or high frequencies or higher frequency harmonics, appropriate precautions are necessary since presence of harmonics produces over voltage and over current on capacitors.

(4) Life expectancy

The life expectancy shows guidelines for a rational designing according to the operating duration of the equipment.

	Life time classification
Motor use	25,000 hours
Discharge lamp use	40,000 hours

- When using capacitors, please select proper types of capacitors which is suitable for applied equipment.
- ⑤ No dust or water should be permitted to remain on the surface of capacitor terminals as this may cause electrical leakage or corrosion.
 - ⑥ To avoid any undue stress, apart from capacitor's resistance to vibrations, it would be better to mount capacitors away from those parts subject to intensive vibrations.